

Miniature Circuit Breakers B4/B6/B10



Technical Datasheet

The IMO range of miniature circuit breakers have been designed for protection of electrical installations against overload and short circuits and are manufactured in accordance with IEC 60898-1

Technical Data

- Handle central-tripping function for circuit fault indicating
- New front design; cover and handle in arc shape
- Contact position indicating window; transparent cover to carry label
- High short circuit capacity
- Suitable for terminal and Pin/Fork type busbar connection
- Finger protected connection terminals
- Handle padlock device



Tripping characteristics in accordance with B, C and D type curves

- Curve B: 3-5 I_n Certification: B4: Semko / CE
- Curve C: 5-10 I_n B10: VDE / Semko / CE
- Curve D: 10-20 I_n



Options & Ordering Codes

B6	B	10	16A	L
MCB Series		Rated Current Amps		
MCB 4.5kA	B4			
MCB 6kA	B6			
MCB 10kA	B10			
Curve Characteristic		Pole Configuration		
Operating characteristic	B	10	Single pole	
Operating characteristic	C	1N	Single pole + Neutral	
Operating characteristic	D	20	Two pole	
		30	Three pole	
		3N	Three pole + Neutral	

L Neutral on the left
Applies to units with neutral.

Specifications

In accordance with	IEC 60898-1	
Certification	CE, SEMKO (only with B4), Kema (only with B10), RCM (only with B4 & B10)	
Pole composition	1P, 1P+N, 2P, 3P, 3P+N	
Tripping Curve	B, C, D	
Calibration temperature	+30°C	
Rated frequency	50/60Hz	
Rated operational voltage	240/415VAC; 60VDC Max	
Rated insulation voltage	240VAC / 415VAC	
Rated impulse withstand voltage:	6.2kV	
Rated short circuit breaking capacity as per IEC 60898-1 and IEC60947-2	B4	1P+N, C curve: 4.5kA
	B6	1P, B curve: 6kA
	B10	1P/2P/3P/3P+N, C & D curve: 10kA
Mechanical lifetime	> 20,000 cycles	
Electrical lifetime	> 8,000 cycles	
Tightening torque	2.0 Nm	
Screw Type	M5	
Terminal capacity	35mm ² solid, 25mm ² stranded conductor (10mm ² for 1P+N)	
Mounting	DIN Rail EN 60715 (EN 50022)	
Protection degree	IP20	
Operating temperature	-5°C +40°C	

Selection Chart

Legend: Contact IMO (grey), 4.5kA (green), 6kA (dark blue), 10kA (dark grey)

Type	B			C			D		
	1	1	1N	2	3	3N	1	2	3
Rated current Amps	2	100	200	200	300	400	100	200	300
	4	100	200	200	300	400	100	200	300
	6	100	200	200	300	400	100	200	300
	10	100	200	200	300	400	100	200	300
	16	100	200	200	300	400	100	200	300
	20	100	200	200	300	400	100	200	300
	25	100	200	200	300	400	100	200	300
	32	100	200	200	300	400	100	200	300
40	100	200	200	300	400	100	200	300	
50	100	200	200	300	400	100	200	300	
63	100	200	200	300	400	100	200	300	
Weight (g/pc)	100	100	200	200	300	400	100	200	300
Packing (Qty)	12	12	6	6	4	3	12	6	4

Single Module Unit

Miniature Circuit Breakers B4/B6/B10

Accessories

Auxiliary Switch	B10-F3
For monitoring the status of the protection device (open/closed)	
1 pole changeover (for C & D curve only)	
Rated current: 6A @ 230VAC & 24VDC or 3A @ 400VAC	
Dielectric Strength: 2000V/1min	
Terminal Capacity: 1-4mm ²	
Mounting on the Left side	

Shunt Trip	B10-S3
Shunt Trip to remotely switch off the protection device	
Rating voltage Ue: AC 110V / 230V / 400V	
Oving Voltage: 70%~110% X Ue	
Mounting on the Left side	

Busbars	
Description	Ref.
Busbar 1 Pole, 80A, Fork Type, 1M	B10BB1F100-1M
Busbar 3 Pole, 80A, Fork Type, 1M	B10BB3F100-1M
Busbar 1 Pole, 80A, Pin Type, 1M	B10BB1P100-1M
Busbar 3 Pole, 80A, Pin Type, 1M	B10BB3P100-1M
End Cap 3 Pole (Fork type only)	B10BBCAP3F100

Terminal Adapter	BA1
------------------	-----

Locking Device	B10-LOCK
4mm padlock max diameter, non included	

Locking Device	B10-TERM
----------------	----------

Dimensions (mm) Miniature Circuit Breakers

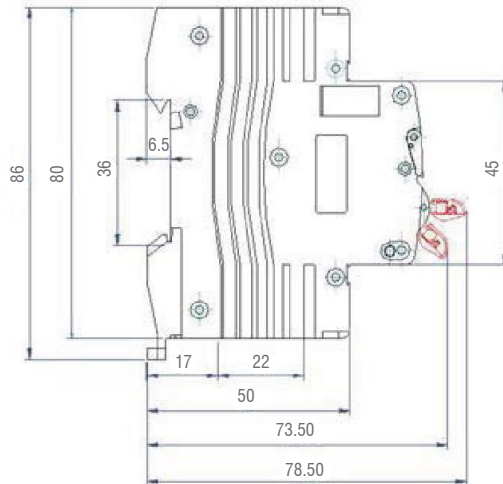
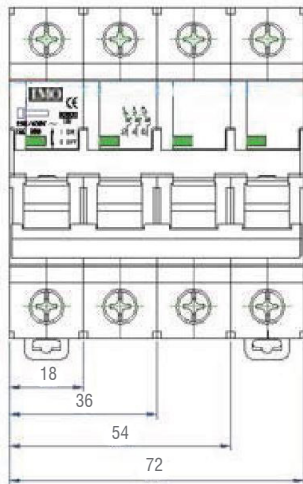

B, C, D Tripping Curve

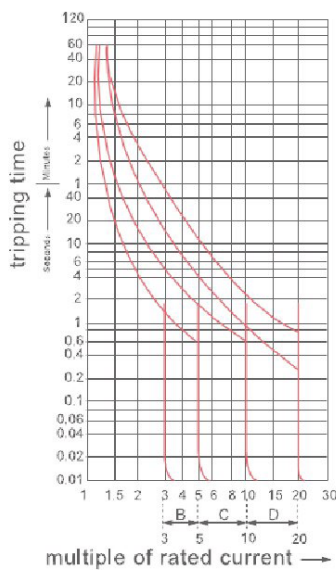

Ambient temperature & Current rating curve

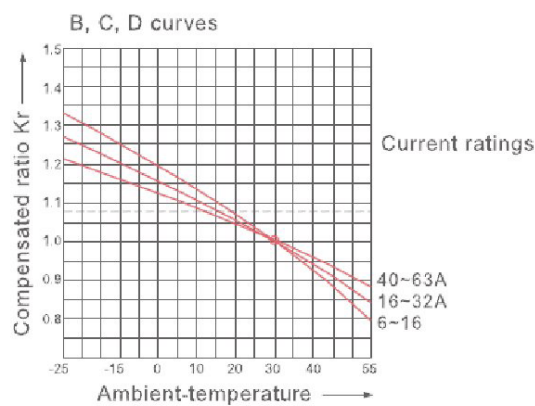

Residual Current Circuit Breakers B10R

The IMO range of Residual Current Circuit Breakers have been designed for protection of electrical installations against earth fault / leakage current and are manufactured in accordance with IEC 61008-1.

Options & Ordering Codes

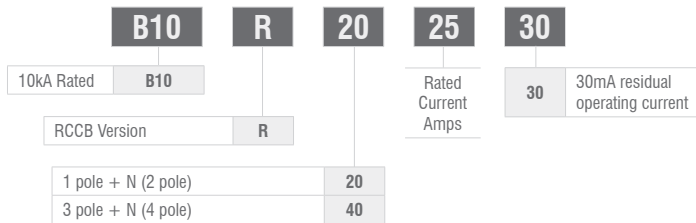

Selection Chart

Type	Operating Characteristics	
	2N	3N
Rated current - Amps	10	
	16	
	25	
	32	
	40	
	63	
Weight (g/pc)	206	412
Packing (Qty)	6	3

Specifications

In accordance with	IEC 61008-1
Certification	CE, SEMKO
Pole composition	2P, 4P
Rated current:	10A (only 2P), 16A, 25A, 32A, 40A, 63A
Residual current characteristics:	AC
Calibration Temperature:	+30°C
Rated frequency:	50/60Hz
Rated voltage:	230VAC/400VAC
Rated residual operating current I _{Δn} :	30mA
Residual tripping current range:	0.5 I _{Δn} ~ 1 I _{Δn}
Rated conditional short circuit current:	10kA
Electrical lifetime	> 4,000 cycles
Fastening torque:	2.0Nm
Terminal capacity:	35mm ² solid, 25mm ² stranded conductor
Mounting on	DIN Rail EN 60715 (EN 50022)
Protection degree:	IP20
Operating temperature:	-25°C - +55°C

Overall & Installation Dimensions

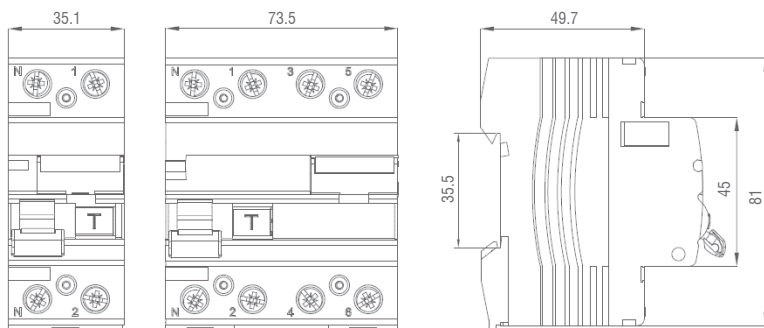

Wiring Diagram

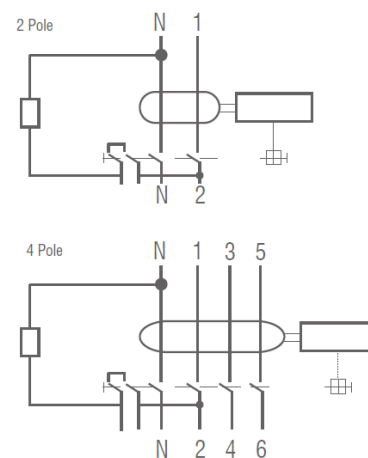

Residual Current Circuit Breakers With Overload Protection

The IMO range of Residual Current-Circuit Breakers with Overload have been designed for protection of electrical installations against earth fault / leakage current, overload and short circuit and are manufactured in accordance with IEC 61009.

RCBO Features

- Provides protection against earth fault / leakage current, overload, short circuit and function of isolation
- Elegant appearance; cover and handle in arc shape.
- Contact position indicating window; transparent cover to carry label
- High short circuit current withstand capacity
- Applicable to terminal and Pin/Fork type busbar connection
- Finger protected connection terminals
- Compatible with MCB accessories range
- Handle padlock device



Options & Ordering Codes

B6	B	R	1N	16	-	30	-	A
10kA Rated	B6			Rated Current Amps				
	Tripping Curve	B				30mA Residual Operating Current		
	Tripping Curve	C				30		
	Tripping Curve	D						
	Residual Current	R					Nil	AC
							Type A	A
			1 Pole + N (2 Pole)	1N				

Tripping characteristics in accordance with B, C and D type curves

- Curve B: 3-5 I_n
- Curve C: 5-10 I_n
- Curve D: 10-20 I_n

Specifications

In accordance with:	IEC 61009
Certification:	CE, SEMKO, RCM
Pole composition:	2P
Residual current characteristics:	AC, A
Tripping Curve:	B, C, D
Calibration temperature:	+30°C
Rated current :	6A, 10A, 16A, 20A, 25A, 32A, 40A
Rated short circuit capacity :	10kA
Rated frequency:	50/60Hz
Rated voltage:	230VAC
Rated residual operating current $I_{\Delta n}$:	30mA
Residual tripping current range:	0.5 $I_{\Delta n}$ ~ 1 $I_{\Delta n}$
Electrical lifetime	> 4,000 cycles
Fastening torque:	2.0Nm
Terminal capacity:	35mm ² solid, 25mm ² stranded conductor
Mounting on	DIN rail EN 60715 (EN 50022)
Protection degree:	IP20
Operating temperature range:	-25°C - +550°C

For Dimensions refer to RCCB Data.
For Tripping Curve refer to MCB.

Dimensions (mm)

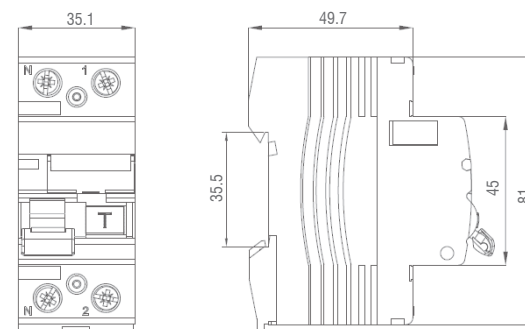

Tripping Curve B

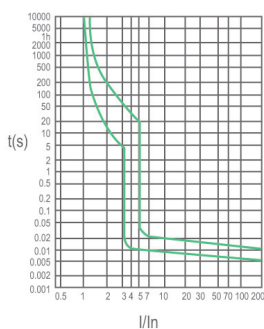

Tripping Curve C

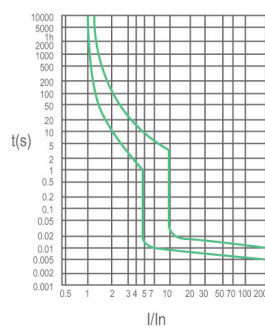

Tripping Curve D

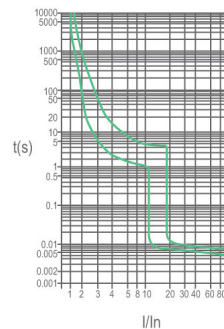

Wiring Diagram

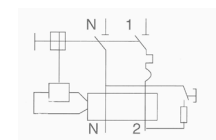

Isolating Switch

The IMO range of isolating switch have been designed to isolate safely your electrical circuit from the main supply and are manufactured in accordance with IEC 60947-3.

- Capable of switch electric circuit with load
- Elegant appearance; cover and handle in arc shape
- Contact position indicating window; transparent cover to carry label
- Applicable to terminal and Pin/Fork type busbar connection
- Finger protected connection terminals
- Compatible with MCB accessories range
- Handle padlock device



Specifications

In accordance with	IEC 60947-3
Certification	CE, SEMKO (63 and 125A only)
Pole composition	1P / 2P / 3P / 4P
Rated current	63A / 100A / 125A
Rated voltage	AC 230 / 400V
Rated frequency	50/60Hz
Rated short circuit capacity	6kA (3kA for 100A version)
Electrical lifetime	> 10,000 cycles
Fastening torque	2.0Nm
Terminal capacity	35mm ² solid, 25mm ² stranded conductor
Protection degree	IP20



Options & Ordering Codes

	BIS	20	63A
Distribution board Isolating Switch	BIS		
1 Pole		10	
2 Pole		20	
3 Pole		30	
4 Pole		40	
Amps 63A & 125A			63A
Amps 100A (red handle)			100C

Selection Chart

3kA
 6kA
 Please contact IMO

	3kA	6kA	Contact IMO	
Poles	1	2	3	4
Rated current Amps	63			
	100			
	125			
Weight (g/pc)	100	200	300	400
Packing (Qty)	12	6	4	3

Dimensions (mm) for 63A & 125A version

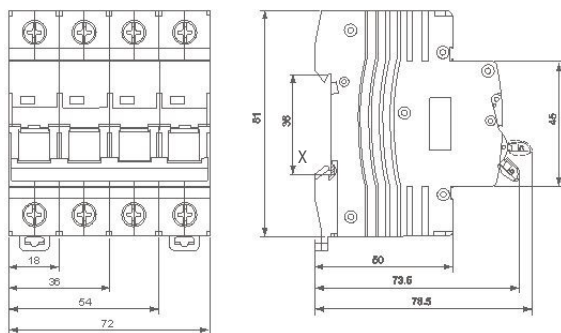

Rating	X
63A	81mm
125A	90mm

Dimensions (mm) for 100A version

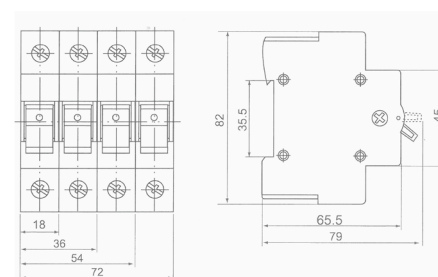

Residual Current Circuit Breakers With Overload Protection 1P+N Single Module

The IMO range of Residual Current-Circuit Breakers with Overload have been designed for protection of electrical installations against earth fault / leakage current, overload and short circuit and are manufactured in accordance with IEC 61009-1.



RCBO Features

- Provides protection against earth fault / leakage current, overload, short circuit and function of isolation
- Elegant appearance; cover and handle in arc shape.
- Single width module RCBO, 119mm tall
- Contact position indicating window; transparent cover to carry label
- High short circuit current withstand capacity
- Applicable to terminal and Pin/Fork type busbar connection (line input only)
- Finger protected connection terminals
- Compatible with MCB accessories range
- Handle padlock device

Tripping characteristics in accordance with B, C and D type curves

- Curve B: 3-5 I_n
- Curve C: 5-10 I_n
- Curve D: 10-20 I_n



Options & Ordering Codes

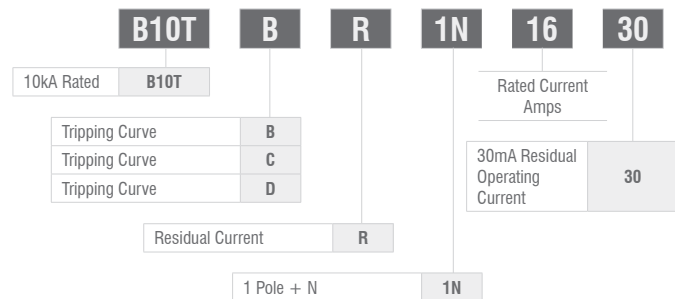

Specifications

In accordance with	IEC 61009-1
Certification	CE
Pole composition	3P+N
Residual current characteristics	AC
Tripping Curve	B, C, D
Rated current	6A, 10A, 16A, 20A, 25A, 32A
Rated short circuit capacity	10 kA
Calibration Temperature	+30°C
Rated frequency	50/60Hz
Rated voltage	230/400VAC
Rated residual operating current $I_{\Delta n}$	30mA
Residual tripping current range	0.5 $I_{\Delta n}$ ~ 1 $I_{\Delta n}$
Electrical lifetime	> 4,000 cycles
Fastening torque	2.0 Nm
Terminal capacity (Live input)	35mm ² solid or 25mm ² stranded
Terminal capacity (output)	10mm ² solid or 6mm ² stranded
Mounting on	DIN rail EN 60715 (EN 50022)
Protection degree	IP20
Operating temperature	-25°C - +55°C

Dimensions (mm) for 1P+N: 1 module (18W x 119H x 69D)
For Tripping Curve refer to MCB.

Selection Chart

Type	Operating Characteristics
Poles	1N
Rated current Amps	6
	10
	16
	20
	25
	32
Weight (g/pc)	178

Wiring Diagram

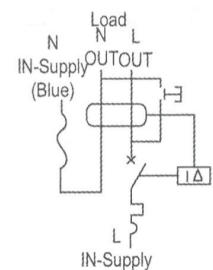

Residual Current Circuit Breakers With Overload Protection 3P+N

The IMO range of Residual Current-Circuit Breakers with Overload have been designed for protection of electrical installations against earth fault / leakage current, overload and short circuit and are manufactured in accordance with IEC 61009-1.

RCBO Features

- Provides protection against earth fault / leakage current, overload, short circuit and function of isolation
- Elegant appearance; cover and handle in arc shape.
- 3P+N version, 5 module width RCBO, 119mm tall
- Contact position indicating window; transparent cover to carry label
- High short circuit current withstand capacity
- Applicable to terminal and Pin/Fork type busbar connection
- Finger protected connection terminals
- Compatible with MCB accessories range
- Handle padlock device

Tripping characteristics in accordance with B, C and D type curves

- Curve B: $3-5 I_n$
- Curve C: $5-10 I_n$
- Curve D: $10-20 I_n$

Specifications

In accordance with: IEC 61009-1
Certification: CE
Pole composition: 3P+N
Residual current characteristics: AC
Tripping Curve: B, C, D
Rated current : 6A, 10A, 16A, 20A, 25A, 32A
Rated short circuit capacity: 10kA
Calibration Temperature: +30°C
Rated frequency: 50/60Hz
Rated voltage: 230/400VAC
Rated residual operating current $I_{\Delta n}$: 30mA
Residual tripping current range: $0.5 I_{\Delta n} \sim 1 I_{\Delta n}$
Electrical lifetime > 4,000 cycles
Fastening torque: 2.0Nm
Terminal capacity: 35mm ² solid, 25mm ² stranded conductor
Mounting on rail EN 60715 (EN 50022)
Protection degree: IP20
Operating temperature: -25°C - +55°C

Dimensions (mm) for 3P+N: 4 module (72W x 81H x 69D) + 1 module (18W x 130H x 69D).
For Tripping Curve refer to MCB.

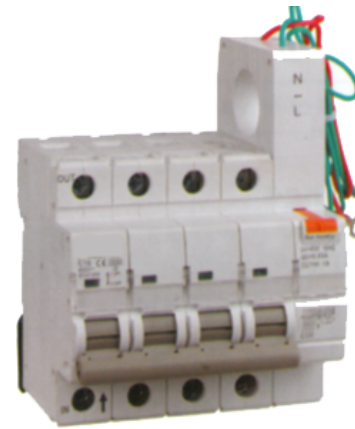

Options & Ordering Codes

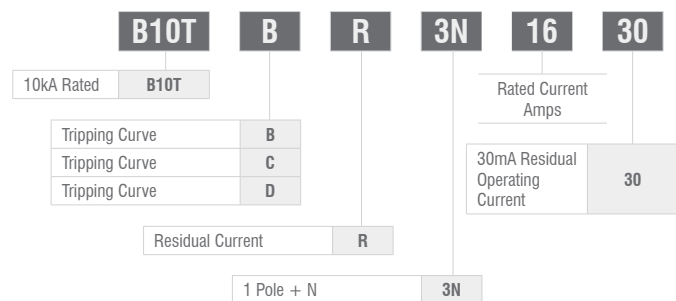

Selection Chart

Type	Operating Characteristics
Poles	3N
Rated current Amps	6
	10
	16
	20
	25
	32
Weight (g/pc)	500

Wiring Diagram

