

# Jaguar NXG Series Inverter Drive



1 Phase 200V–240V 50/60Hz 0.2~4kW (1/4~5.5HP)  
 3 Phase 200V–240V 50/60Hz 0.2~15kW (1/4~20HP)  
 3 Phase 380V–480V 50/60Hz 0.4~22kW (1/2~30HP)

- Torque Vector Control
- Up to 200% Starting Torque
- Slimline Compact Design
- Dual Rated for Heavy Duty & Normal Duty applications
- Asynchronous & Synchronous motor control
- Safe Torque Off (STO) – Dual Channel & SIL3 rated
- Fire Mode as standard
- Built-in USB Type C port
- Modbus RTU as standard
- Optional all-in-one communication card:
  - PROFINET, - Ethernet IP, - EtherCAT, - Modbus TCP
- 5 Year Warranty



## Ordering Information

1 Phase 200V–240V 50/60Hz 0.2~4kW (0.27~5.5HP)

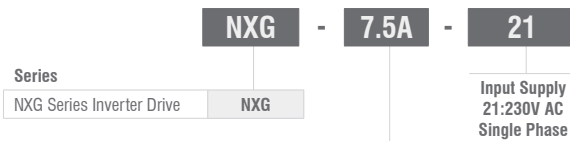

**Inverter Output Current (A)**

Output Power		Output Current
kW	HP	(A)
0.2	1/4	1.5
0.4	1/2	2.5
0.75	1	4.2
1.1	1 1/2	6.5
1.5	2	7.5
2.2	3	10
4	5 1/2	16

3 Phase 380V–480V 50/60Hz 0.4~22kW (0.5~30HP)

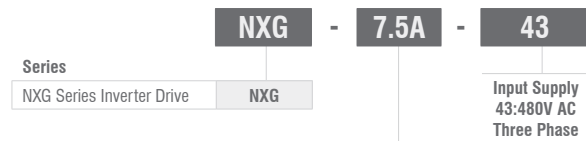

**Inverter Output Current (A)**

Output Power		Output Current
kW	HP	(A)
0.4	1/2	1.5
0.75	1	2.5
1.1	1 1/2	3
1.5	2	4.2
2.2	3	5.5
3	4	7.5
4	5 1/2	9.5
5.5	7 1/2	14
7.5	10	18.5
11	15	25
15	20	32
18.5	25	38
22	30	45

3 Phase 200V–240V 50/60Hz 0.2~15kW (0.27~20HP)

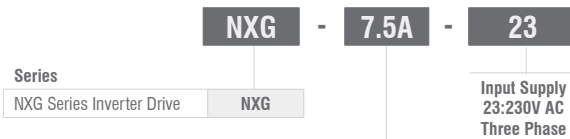

**Inverter Output Current (A)**

Output Power		Output Current
kW	HP	(A)
0.2	1/4	1.5
0.4	1/2	2.5
0.75	1	4.2
1.1	1 1/2	6.5
1.5	2	7.5
2.2	3	10
4	5 1/2	16
5.5	7 1/2	20
7.5	10	30
11	15	42
15	20	55

# Jaguar NXG Series

## Inverter Drive



### Technical Specifications and Features

Function Description		Specification
Power Input	Input Voltage (V)	AC 1PH 200V(-15%)–240V(+10%) AC 3PH 200V(-15%)–240V(+10%) AC 3PH 380V(-15%)–480V(+10%)
	Input Frequency (Hz)	50Hz/60Hz, allowable range: 47-63Hz
Power Output	Output Voltage (V)	0-Input voltage
	Output Frequency (Hz)	0-599Hz
Technical Control Performance	Control Mode	V/F control, Sensorless Vector Control (SVC)
	Motor Type	Asynchronous motor, Permanent-magnet synchronous motor
	Dual Rating	Yes, Constant Torque (Heavy Duty - HD) / Variable Torque (Normal Duty - ND)
	Speed Regulation Ratio	Asynchronous motor 1:100 (SVC); Synchronous motor 1:50 (SVC)
	Speed Control Accuracy	±0.2% (SVC)
	Speed Fluctuation	±0.3% (SVC)
	Torque Response	<10ms (SVC)
	Torque Control Accuracy	5% (SVC)
	Starting Torque	Asynchronous motor: 0.5Hz / 200% (SVC) Synchronous motor: 2.5Hz / 150% (SVC)
	Overload Capacity	Constant Torque Load: 150%: 1 min; 180%: 10s Variable Torque Load: 110%: 1 min; 150%: 10s
Running Control Performance	Frequency Setup Mode	Digital, Analog, Pulse Frequency, Multi-step speed running, Simple PLC, PID, Modbus communication, Ethernet-based communication.
	Automatic Voltage Regulation Function	Keeps the output voltage constant when grid voltage changes
	Fault Protection Function	Provides over 30 kinds of fault protection functions: overcurrent, overvoltage, undervoltage, over-temperature, phase loss and overload, etc.
	Speed Tracking Restart	Realise impact-free starting of the motor in rotating
	PID Control	Yes
Peripheral Interface	Analog Input	2 (AI1: 0-10V/0-20mA; AI2: 0-10V/0-20mA) + 1 Built-in Potentiometer
	Analog Output	1 (AO1: 0-10V/0-20mA)
	Digital Input	4x DI, 1x High Speed Inputs, DI4 can be configured as PTC input for motor temperature monitoring
	Digital Output	1x DO
	Relay Output	1x Programmable relay output, NO/NC contact
	Communication Interface	Modbus RTU as standard, 1x RS485 (non-isolated), 1x USB Type C
	STO Input	2x Redundant Input
	Keypads	Built in LED Keypad; Optional Remote LED Keypad or Optional Advanced LCD Keypad with copy function
Other	Installation	Wall mounting, Flange mounting, Optional DIN Rail mounting
	Temperature	-10°C to +50°C (No derating required between -10°C to +50°C)
	Protection Level	IP20
	Cooling Mode	230V Voltage class: Natural cooling for 0.75kW and lower 480V Voltage class: Natural cooling for 1.1kW and lower Others: Forced Air Cooling
	Braking Unit	Standard built-in braking unit
	DC Injection Braking	Yes
	Motor Auto-Tune	Yes, Supports Static and Dynamic Modes
	STO Level	SIL3 / PL e / CAT 3
	EMC Filter	Removable built-in C2 filter is standard on 1 Phase 200V–240V, 0.2–4kW (0.27–5.5HP) and removable built-in C3 filter is standard on all 3 phase versions. Optional C2 Filters are available for all 3 phase versions.

# Jaguar NXG Series

## Inverter Drive



### Technical Specifications - Electrical Ratings

Model	Constant Torque Heavy Duty (HD)				Variable Torque Normal Duty (ND)			
	Output Power		Rated Input Current	Rated Output Current	Output Power		Rated Input Current	Rated Output Current
	kW	HP	A	A	kW	HP	A	A
<b>AC 1PH 200V-240V</b>								
NXG-1.5A-21	0.2	¼	3.9	1.5	0.4	½	5.2	2
NXG-2.5A-21	0.4	½	5.3	2.5	0.75	1	7.4	3.3
NXG-4.2A-21	0.75	1	8.8	4.2	1.1	1½	11	5.1
NXG-6.5A-21	1.1	1½	13.2	6.5	1.5	2	13.4	7.5
NXG-7.5A-21	1.5	2	14.2	7.5	2.2	3	18.8	9.8
NXG-10A-21	2.2	3	20.6	10	3	4	23.8	12.5
NXG-16A-21	4	5½	32	16	-	-	-	-
<b>AC 3PH 200V-240V</b>								
NXG-1.5A-23	0.2	¼	2.2	1.5	0.4	½	3.3	2
NXG-2.5A-23	0.4	½	4.1	2.5	0.75	1	5.6	3.3
NXG-4.2A-23	0.75	1	6.8	4.2	1.1	1½	8.1	5.1
NXG-6.5A-23	1.1	1½	10.3	6.5	1.5	2	11.5	7.5
NXG-7.5A-23	1.5	2	9.3	7.5	2.2	3	11.8	9.8
NXG-10A-23	2.2	3	12	10	3	4	13.7	12.5
NXG-16A-23	4	5½	20	16	5.5	7½	26	21
NXG-20A-23	5.5	7½	21.7	20	7.5	10	28	26
NXG-30A-23	7.5	10	33	30	11	15	43	39
NXG-42A-23	11	15	44	42	-	-	-	-
NXG-55A-23	15	20	60	55	18.5	25	72	64
<b>AC 3PH 380V-480V</b>								
NXG-1.5A-43	0.4	½	2.7	1.5	0.75	1	3.9	2
NXG-2.5A-43	0.75	1	4.5	2.5	1.1	1½	6	3.3
NXG-3A-43	1.1	1½	5.8	3	1.5	2	6.9	3.7
NXG-4.2A-43	1.5	2	7.6	4.2	2.2	3	8.6	5.5
NXG-5.5A-43	2.2	3	9.62	5.5	3	4	10.4	7
NXG-7.5A-43	3	4	11.4	7.5	4	5½	12.8	9.5
NXG-9.5A-43	4	5½	15.3	9.5	5.5	7½	17.2	11.5
NXG-14A-43	5.5	7½	22.1	14	7.5	10	28.1	18
NXG-18.5A-43	7.5	10	25	18.5	11	15	26.8	21
NXG-25A-43	11	15	36	25	15	20	46	32
NXG-32A-43	15	20	46	32	18.5	25	55	38
NXG-38A-43	18.5	25	57	38	22	30	68	45
NXG-45A-43	22	30	62	45	30	40	72	58

# Jaguar NXG Series

## Inverter Drive



### Technical Specifications - Dimensions and Mounting

Model	Frame Size	Outline Dimensions mm (Inches)			Mounting Hole Pitch mm (Inches)		Net Weight	Gross Weight	Mounting Hole Diameter
		W1	H1	D1	W2	H2	kg	kg	mm
<b>AC 1PH 200V-240V</b>									
NXG-1.5A-21	A	60 (2.36)	190 (7.48)	155 (6.10)	36 (1.42)	180 (7.09)	1.23	1.34	Ø5
NXG-2.5A-21									
NXG-4.2A-21									
NXG-6.5A-21	B	70 (2.76)	190 (7.48)	155 (6.10)	36 (1.42)	180 (7.09)	1.27	1.47	Ø5
NXG-7.5A-21									
NXG-10A-21									
NXG-16A-21	C	90 (3.54)	235 (9.25)	155 (6.10)	70 (2.76)	220 (8.66)	2.05	2.26	Ø6
<b>AC 3PH 200V-240V</b>									
NXG-1.5A-23	A	60 (2.36)	190 (7.48)	155 (6.10)	36 (1.42)	180 (7.09)	1.23	1.34	Ø5
NXG-2.5A-23									
NXG-4.2A-23									
NXG-6.5A-23	B	70 (2.76)	190 (7.48)	155 (6.10)	36 (1.42)	180 (7.09)	1.23	1.34	Ø5
NXG-7.5A-23									
NXG-10A-23									
NXG-16A-23	C	90 (3.54)	235 (9.25)	155 (6.10)	70 (2.76)	220 (8.66)	2.05	2.26	Ø6
NXG-20A-23									
NXG-30A-23									
NXG-42A-23	D	130 (5.12)	250 (9.84)	185 (7.28)	100 (3.94)	237 (9.33)	3.55	4.05	Ø6
NXG-55A-23	E	160 (6.30)	300 (11.81)	190 (7.48)	130 (5.12)	287 (11.30)	4.9	5.4	Ø6
<b>AC 3PH 380V-480V</b>									
NXG-1.5A-43	A	60 (2.36)	190 (7.48)	155 (6.10)	36 (1.42)	180 (7.09)	1.23	1.34	Ø5
NXG-2.5A-43									
NXG-3A-43									
NXG-4.2A-43	B	70 (2.76)	190 (7.48)	155 (6.10)	36 (1.42)	180 (7.09)	1.23	1.34	Ø5
NXG-5.5A-43									
NXG-7.5A-43									
NXG-9.5A-43	C	90 (3.54)	235 (9.25)	155 (6.10)	70 (2.76)	220 (8.66)	2.05	2.26	Ø6
NXG-14A-43									
NXG-18.5A-43									
NXG-25A-43	D	130 (5.12)	250 (9.84)	185 (7.28)	100 (3.94)	237 (9.33)	3.55	4.05	Ø6
NXG-32A-43									
NXG-38A-43									
NXG-45A-43	E	160 (6.30)	300 (11.81)	190 (7.48)	130 (5.12)	287 (11.30)	4.9	5.4	Ø6

### Certifications and Compliance

Category	Standard
STO (Safe Torque Off)	EN ISO 13849-1:2023 (Cat. 3, PL e)
	EN IEC 62061:2021 (SIL3)
	EN 61800-5-2:2017
STO Safety Classification	SIL3 / PL e / CAT.3
CE Compliance	EN 61800-5-1:2007/A11:2021
	EN IEC 61800-3:2023 / IEC 61800-3:2022
EU Directives	2014/35/EU – Low Voltage Directive
	2014/30/EU – Electromagnetic Compatibility Directive

# Jaguar NXG Series

## Inverter Drive



### Dimensions mm (Inch) & Frame Sizes

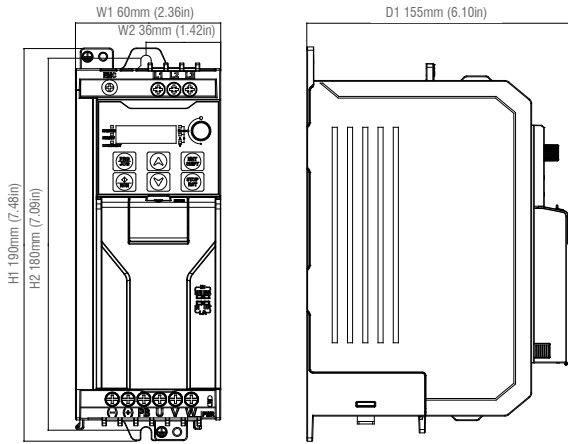

Frame Size A

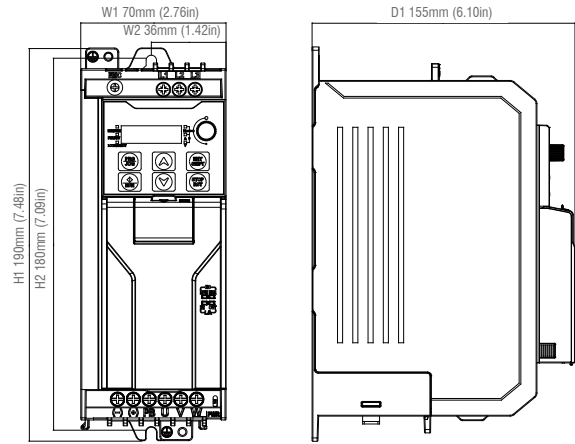

Frame Size B

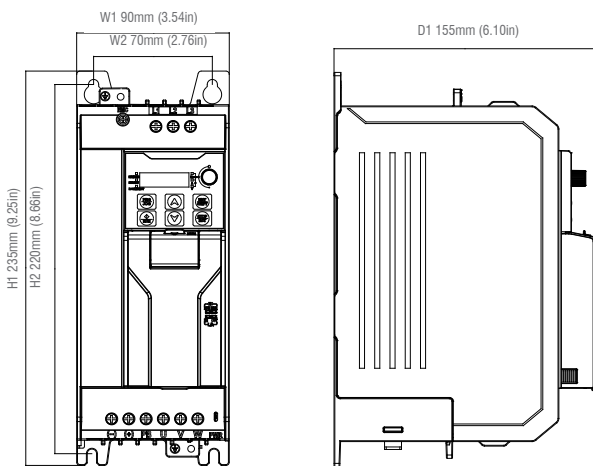

Frame Size C

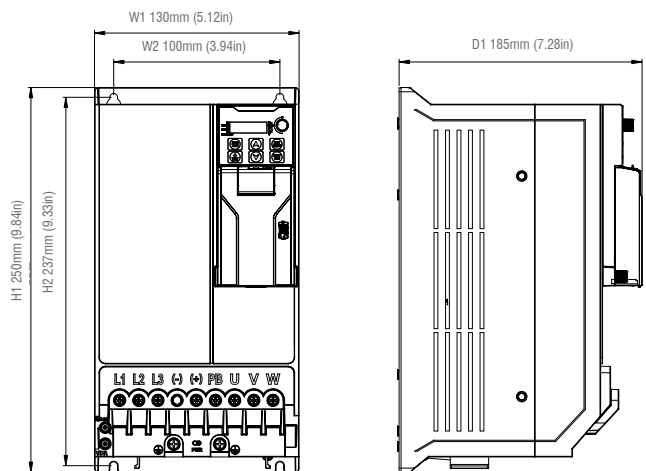

Frame Size D

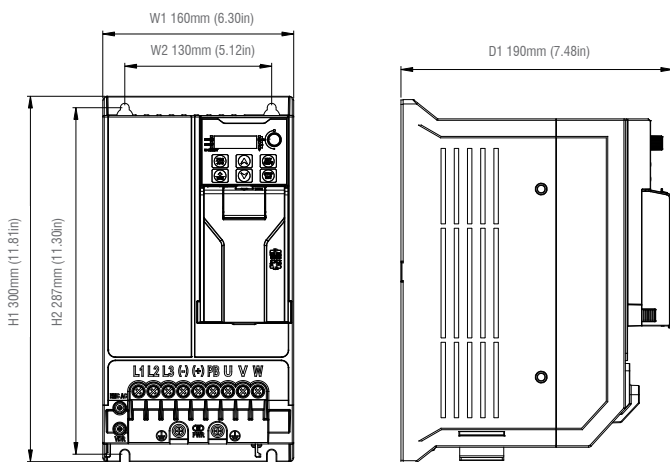

Frame Size E

# Jaguar NXG Series Inverter Drive



## Control Connections

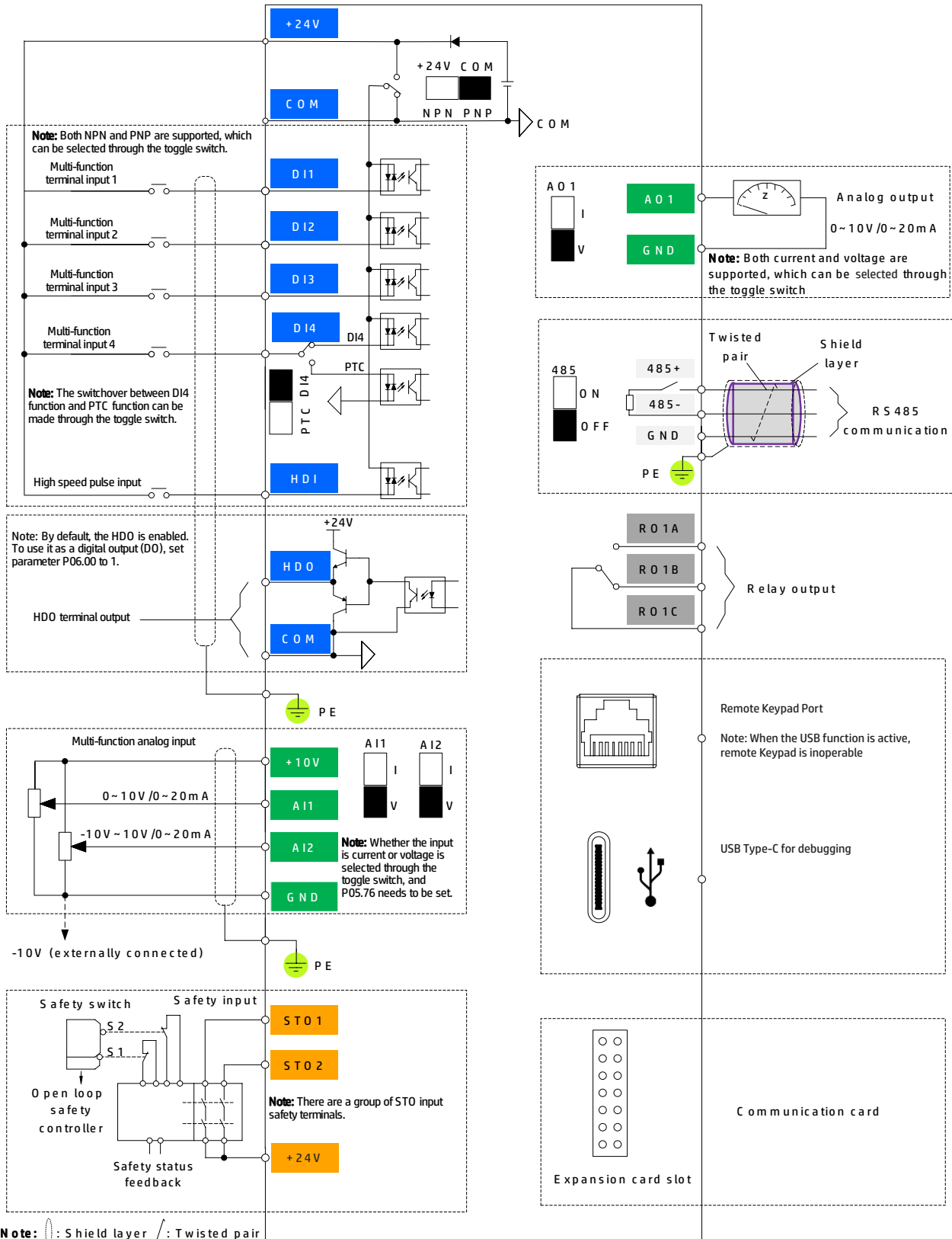

# Jaguar NXG Series

## Inverter Drive



### Accessories

Model	Input Reactor	Output Reactor	Breaker	Fuse	Contactors
			A	A	A
<b>AC 1PH 200V-240V</b>					
NXG-1.5A-21	-	OCLC-6A-4	6	8	9
NXG-2.5A-21	-	OCLC-6A-4	10	16	9
NXG-4.2A-21	-	OCLC-6A-4	16	25	12
NXG-6.5A-21	-	OCLC-10A-4	20	25	18
NXG-7.5A-21	-	OCLC-10A-4	25	32	25
NXG-10A-21	-	OCLC-14A-4	32	40	32
NXG-16A-21	-	OCLC-20A-4	40	50	38
<b>AC 3PH 200V-240V</b>					
NXG-1.5A-23	ACLC-6A-4	OCLC-6A-4	6	6	9
NXG-2.5A-23	ACLC-6A-4	OCLC-6A-4	6	8	9
NXG-4.2A-23	ACLC-14A-4	OCLC-6A-4	10	16	9
NXG-6.5A-23	ACLC-14A-4	OCLC-10A-4	16	20	12
NXG-7.5A-23	ACLC-14A-4	OCLC-10A-4	20	25	18
NXG-10A-23	ACLC-14A-4	OCLC-20A-4	25	32	25
NXG-16A-23	ACLC-25A-4	OCLC-20A-4	40	40	32
NXG-20A-23	ACLC-32A-4	OCLC-32A-4	50	50	40
NXG-30A-23	ACLC-40A-4	OCLC-40A-4	63	80	65
NXG-42A-23	ACLC-51A-4	OCLC-50A-4	80	100	65
NXG-55A-23	ACLC-90A-4	OCLC-75A-4	100	125	95
<b>AC 3PH 380V-480V</b>					
NXG-1.5A-43	ACLC-6A-4	OCLC-6A-4	6	6	9
NXG-2.5A-43	ACLC-6A-4	OCLC-6A-4	10	8	9
NXG-3A-43	ACLC-6A-4	OCLC-6A-4	10	10	9
NXG-4.2A-43	ACLC-14A-4	OCLC-6A-4	16	16	12
NXG-5.5A-43	ACLC-14A-4	OCLC-10A-4	16	16	12
NXG-7.5A-43	ACLC-14A-4	OCLC-10A-4	20	25	18
NXG-9.5A-43	ACLC-20A-4	OCLC-14A-4	20	25	18
NXG-14A-43	ACLC-32A-4	OCLC-20A-4	32	40	32
NXG-18.5A-43	ACLC-32A-4	OCLC-20A-4	40	50	32
NXG-25A-43	ACLC-51A-4	OCLC-35A-4	50	63	50
NXG-32A-43	ACLC-51A-4	OCLC-40A-4	63	80	65
NXG-38A-43	ACLC-70A-4	OCLC-50A-4	80	100	65
NXG-45A-43	ACLC-70A-4	OCLC-60A-4	100	125	95

#### Notes:

It is recommended to use B type breakers for all the IMO inverter drives.

The input reactors and output reactors are CE approved only.

### Accessories

Part Number	Part Description
NXG-KP-LED	LED keypad
NXG-KP-LCD	LCD keypad
NXG-KP-MB	Keypad mounting bracket
NXG-E-ETH	Communication card Supported protocols are 1. PROFINET 2. EtherCAT 3. Ethernet IP 4. Modbus TCP
NXG-DRB-1	DIN rail bracket
NXG-MF-3	Flange mount kit – Frame C
NXG-MF-4	Flange mount kit – Frame D
NXG-MF-5	Flange mount kit – Frame E

Part Number	Part Description
NXG-EGP-1	Earthing Gland Plate- Frame A,B
NXG-EGP-3	Earthing Gland Plate- Frame C
NXG-EGP-4	Earthing Gland Plate- Frame D
NXG-EGP-5	Earthing Gland Plate- Frame E
NXG-NK1-1	NEMA 1 Kit – Frame A
NXG-NK1-2	NEMA 1 Kit – Frame B
NXG-NK1-3	NEMA 1 Kit – Frame C
NXG-NK1-4	NEMA 1 Kit – Frame D
NXG-NK1-5	NEMA 1 Kit – Frame E