

# SmartStix GCL-DT4A

High Speed Remote I/O for the i3 Family  
 16 DC Inputs (24VDC, positive logic),  
 16 DC Outputs (24VDC, positive logic, 0.5A)



## 1 GENERAL SPECIFICATIONS

General Specifications				
Storage Temperature	-25° to 70° C	Operating and Storage Humidity	5 to 95% Non-condensing	
Operating Temperature	0° to 55° C	Pollution degree	2 or lower	
Atmosphere	Free from corrosive gases and excessive dust	Cooling method	Self-cooling	
Vibration				
Occasional Vibration				
Frequency	Acceleration	Amplitude	Sweep Count	
10 ≤ f < 57 Hz	-	0.075 mm	10 times in each direction for X,Y,Z	
57 ≤ f ≤ 150 Hz	9.8 m/s <sup>2</sup> {1G}	-		
Continuous Vibration				
Frequency	Acceleration	Amplitude	Sweep Count	
10 ≤ f < 57 Hz	-	0.035 mm	10 times in each direction for X,Y,Z	
57 ≤ f ≤ 150 Hz	4.9 m/s <sup>2</sup> {0.5G}	-		
Shocks				
Maximum shock acceleration	147 m/s <sup>2</sup> {15G}			
Duration Time	11 ms.			
Pulse Wave	Half sine wave pulse (3 times in each of X, Y, Z directions)			
Noise Immunity				
Square wave impulse noise	AC: ± 1,500VDC DC: ± 900VDC			
Electrostatic Discharge	Voltage: 4kV (contact discharge)			
Radiated electromagnetic field	27 – 500MHz, 10V/m			
Fast Transient Burst Noise	Severity level	All power modules	Digital I/Os (Ue ≥ 24V)	Digital I/Os (Ue < 24 V) Analogue I/Os Communication I/Os
	Voltage	2 kV	1 kV	0.25 kV

## 2 DIMENSIONS

### a. DT4A

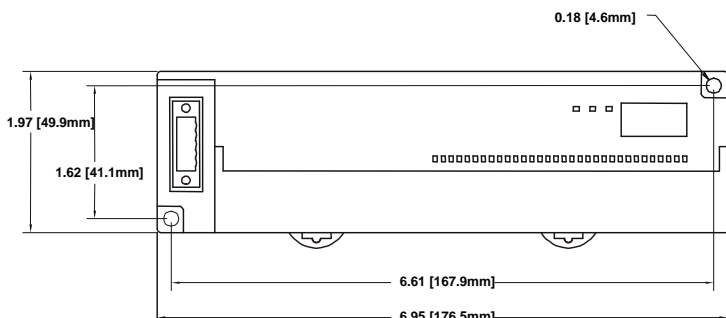

### b. Terminal Strips

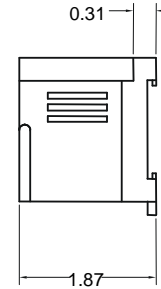

GCL - With Removable Strip

## 3 NETWORK CABLE

For detailed wiring information, refer to the Remote I/O Tutorial.  
<http://www.imopc.com/download/912/i3-tutorial-remote-i-o.html>

Pin	Description	Recommended Cable	
RED	1 V+	Thick: (Max Distance = 500m)	Belden 3082A
WHT	2 CAN_H		
NC	3 No Connection	Thin: (Max Distance = 100m)	Belden 3084A
BLU	4 CAN_L		
BLK	5 V-		

## 4 ID SWITCHES (SETTING iCAN NETWORK IDs)

iCAN Network IDs are set using the hexadecimal number system from 01 to FD. The decimal equivalent is 1-253. Refer to Section 8, which shows the decimal equivalent of hexadecimal numbers. Set a unique Network ID by inserting a small Phillips screwdriver into the two *identical* switches. **Note:** The iCAN Baud Rate for SmartStix I/O is fixed at 125KBaud.

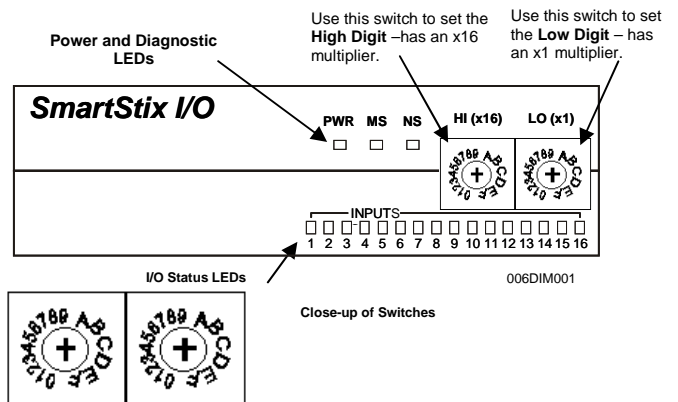

5 LEDs

a. Diagnostic LED Indicators

Diagnostic LED	State	Meaning
MS: (indicates fault status of Module)	Solid Red	RAM or ROM test failed
	Blinking Red	I/O test failed
	Blinking Green	Module is in power-up state
	Solid Green	Module is running normally
NS: (indicates fault status of Network)	Solid Red	Network Ack or Dup ID test failed
	Blinking Red	Network ID test failed
	Blinking Green	Module is in Life Expectancy default state
	Solid Green	Network is running normally

b. Status LED Indicators

The Power Status LED illuminates Red when power is applied to the module. There are I/O Status LED indicators for each of the Digital I/O points, which illuminate Red when an I/O point is ON.

7 INTERNAL WIRING

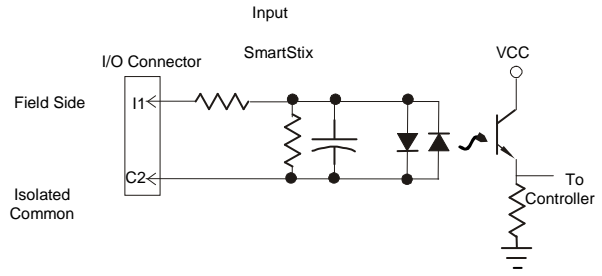

6 WIRING

a. 16 DC IN, Positive Logic/16 DC OUT, Positive Logic

DT4A IN			
Number of input points	16	OFF to ON Response	0 - 3ms. or less
Rated Input Current	7mA	ON to OFF Response	0 - 3ms. or less
ON Voltage Level	19VDC or less	Common Terminal	16 points / COM
OFF Voltage Level	6VDC or less	Operating Indicator	LED turns on during ON state of input
Input Characteristics	Bidirectional	External Connections	Terminal block connector (M3 x 6 screws)
Isolation Method	Photo Coupler		
DT4A OUT			
Number of output points	16	External Power Supply	Voltage: 24VDC ± 10%(ripple voltage: 4Vp-p or less) Current: 30mA (TYP, All points ON)
Commons per Module	1		
Operating Voltage	24VDC	OFF to ON Response	2ms.
Rated Load Voltage	24VDC	ON to OFF Response	2ms.
OFF Leakage Current	0.1mA or less	Max. Inrush Current per channel	1A, 10ms
Rated Voltage	11 - 25 VDC	Max. Load Current per channel	0.5A Max. per output 3A per common
Internal power Consumption (mA)	350	Output Type	Sourcing
Common Method	16 points / COM	Weight	10.16 oz. (288 g)

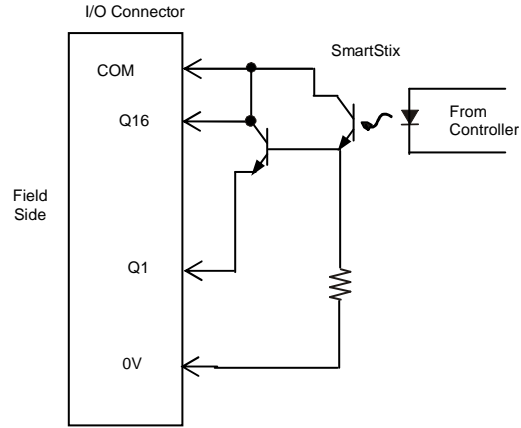

8 DECIMAL (DEC) TO HEXADEXIMAL (HEX) CONVERSION TABLE

Dec	Hex		Dec	Hex		Dec	Hex	
	HI	LO		HI	LO		HI	LO
0	0	0	86	5	6	172	A	C
1	0	1	87	5	7	173	A	D
2	0	2	88	5	8	174	A	E
3	0	3	89	5	9	175	A	F
4	0	4	90	5	A	176	B	0
5	0	5	91	5	B	177	B	1
6	0	6	92	5	C	178	B	2
7	0	7	93	5	D	179	B	3
8	0	8	94	5	E	180	B	4
9	0	9	95	5	F	181	B	5
10	0	A	96	6	0	182	B	6
11	0	B	97	6	1	183	B	7
12	0	C	98	6	2	184	B	8
13	0	D	99	6	3	185	B	9
14	0	E	100	6	4	186	B	A
15	0	F	101	6	5	187	B	B
16	1	0	102	6	6	188	B	C
17	1	1	103	6	7	189	B	D
18	1	2	104	6	8	190	B	E
19	1	3	105	6	9	191	B	F
20	1	4	106	6	A	192	C	0
21	1	5	107	6	B	193	C	1
22	1	6	108	6	C	194	C	2
23	1	7	109	6	D	195	C	3
24	1	8	110	6	E	196	C	4
25	1	9	111	6	F	197	C	5
26	1	A	112	7	0	198	C	6
27	1	B	113	7	1	199	C	7
28	1	C	114	7	2	200	C	8
29	1	D	115	7	3	201	C	9
30	1	E	116	7	4	202	C	A
31	1	F	117	7	5	203	C	B
32	2	0	118	7	6	204	C	C
33	2	1	119	7	7	205	C	D
34	2	2	120	7	8	206	C	E
35	2	3	121	7	9	207	C	F
36	2	4	122	7	A	208	D	0
37	2	5	123	7	B	209	D	1
38	2	6	124	7	C	210	D	2
39	2	7	125	7	D	211	D	3
40	2	8	126	7	E	212	D	4
41	2	9	127	7	F	213	D	5

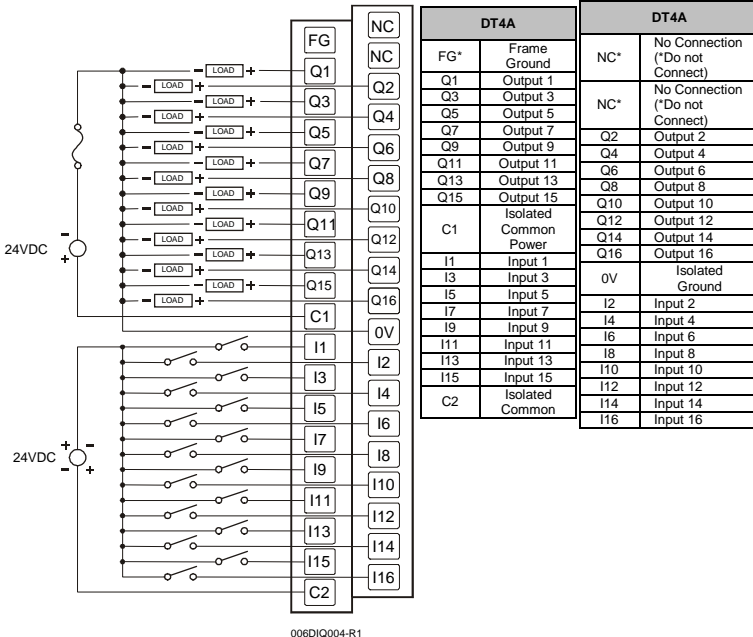

42	2	A	128	8	0	214	D	6
43	2	B	129	8	1	215	D	7
44	2	C	130	8	2	216	D	8
45	2	D	131	8	3	217	D	9
46	2	E	132	8	4	218	D	A
47	2	F	133	8	5	219	D	B
48	3	0	134	8	6	220	D	C
49	3	1	135	8	7	221	D	D
50	3	2	136	8	8	222	D	E
51	3	3	137	8	9	223	D	F
52	3	4	138	8	A	224	E	0
53	3	5	139	8	B	225	E	1
54	3	6	140	8	C	226	E	2
55	3	7	141	8	D	227	E	3
56	3	8	142	8	E	228	E	4
57	3	9	143	8	F	229	E	5
58	3	A	144	9	0	230	E	6
59	3	B	145	9	1	231	E	7
60	3	C	146	9	2	232	E	8
61	3	D	147	9	3	233	E	9
62	3	E	148	9	4	234	E	A
63	3	F	149	9	5	235	E	B
64	4	0	150	9	6	236	E	C
65	4	1	151	9	7	237	E	D
66	4	2	152	9	8	238	E	E
67	4	3	153	9	9	239	E	F
68	4	4	154	9	A	240	F	0
69	4	5	155	9	B	241	F	1
70	4	6	156	9	C	242	F	2
71	4	7	157	9	D	243	F	3
72	4	8	158	9	E	244	F	4
73	4	9	159	9	F	245	F	5
74	4	A	160	A	0	246	F	6
75	4	B	161	A	1	247	F	7
76	4	C	162	A	2	248	F	8
77	4	D	163	A	3	249	F	9
78	4	E	164	A	4	250	F	A
79	4	F	165	A	5	251	F	B
80	5	0	166	A	6	252	F	C
81	5	1	167	A	7	253	F	D
82	5	2	168	A	8	254	F	E
83	5	3	169	A	9	255	F	F
84	5	4	170	A	A			
85	5	5	171	A	B			

## 9 INSTALLATION / SAFETY

- a. All applicable codes and standards need to be followed in the installation of this product.
- b. For I/O wiring (discrete), use the following wire type or equivalent: Belden 8441 or equivalent.
- c. For detailed installation information, refer to Remote I/O Tutorial:  
<http://www.imopc.com/download/912/i3-tutorial-remote-i-o.html>



**Warning:** Consult user documentation.



**Warning:** Electrical Shock Hazard.

**Warning:** To protect the module and associated wiring from load faults, use external fuse (5 A).

**Warning:** Connecting high voltage to any I/O pin may cause high voltage to appear at other I/O pins.

**Warning:** Wiring the line side of the AC source to loads connected to outputs 0 through 15 and the neutral side of the AC source to the output common(s) would create a Negative Logic condition, which may be considered an unsafe practice.

## 10 TECHNICAL ASSISTANCE

For assistance and manual updates, contact Technical Support: [automation@imopc.com](mailto:automation@imopc.com)